

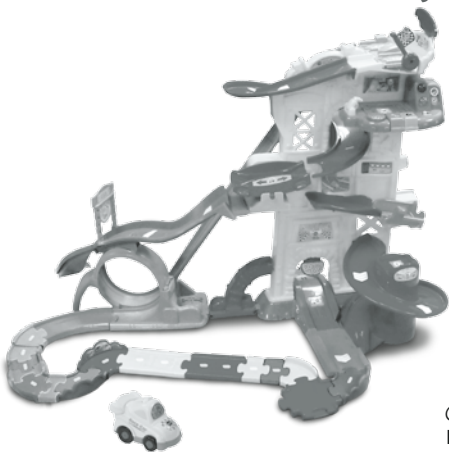

**vtech**<sup>®</sup>

User's Manual

**Go!Go!  
Smart Wheels**<sup>®</sup>  
*Playtime with miles of learning!*<sup>™</sup>

**Ultimate Amazement Park Playset**<sup>™</sup>



© 2015 VTech  
Printed in China  
91-002921-013 

Dear Parent,

Welcome to the world of **Go! Go! Smart Wheels**®! We're excited you've decided to ride along with us and explore all that **Go! Go! Smart Wheels**® has to offer. These toys have been designed to give your child a thrilling learning experience with hours and hours of fun as well.

**Go! Go! Smart Wheels**® features vehicles that interact with your child by lighting up, singing and talking, while teaching your child letters and vehicle names (each sold separately). There are other surprises in store, too! With our innovative **SmartPoint**® technology, available on **Go! Go! Smart Wheels**® playsets (each sold separately), your child will smile as they hear **SmartPoint**® vehicles respond to each unique **SmartPoint**® location with singing, sound effects and fun phrases.

Our **Go! Go! Smart Wheels**® playsets also feature buttons, gears and other mechanical features to encourage the development of your child's fine motor skills. Many of the playsets also have tracks that can be arranged in endless ways, stimulating your child's creativity. In addition, all the **Go! Go! Smart Wheels**® playsets connect to other playsets in the collection, so there's no end to what your child can do!

With **Go! Go! Smart Wheels**®, it's playtime with miles of learning!

Sincerely,  
Your friends at **VTech**®

To learn more about **VTech**® toys, visit [vtechkids.com](http://vtechkids.com)

# INTRODUCTION

Thank you for purchasing the **VTech® Go! Go! Smart Wheels® Ultimate Amazement Park Playset™** learning toy!

Pull the flag and zoom around obstacles with the **Go! Go! Smart Wheels® Ultimate Amazement Park Playset™** by **VTech®**! Develop language and motor skills while racing through three incredible features including a 360 degree loop, spiral and ramp!

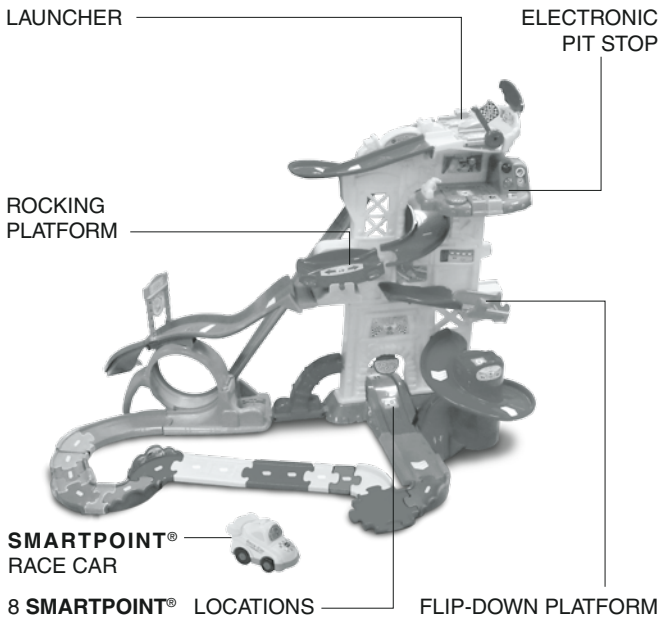

# INCLUDED IN THIS PACKAGE



One **SmartPoint**<sup>®</sup>  
race car



One **SmartPoint**<sup>®</sup>  
electronic pit stop



One **SmartPoint**<sup>®</sup>  
tower base

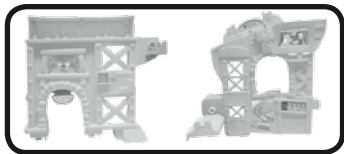

Two tower pieces



One **SmartPoint**<sup>®</sup>  
launcher



Two C-shaped tracks



Two spiral tracks with  
**SmartPoint**<sup>®</sup> platform



One **SmartPoint**<sup>®</sup>  
loop base



Two long straight tracks



Two ramp tracks

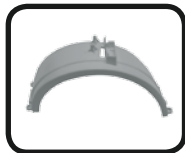

One semicircular  
loop track

INCLUDED IN THIS PACKAGE





One base support  
One rocking platform  
One flip-down **SmartPoint**® platform

One mini ramp track  
One short curved track  
One short straight track



One small track support  
One flag piece  
One start sign

One gate  
One flipping board  
10 screws



Two adjustable track pieces  
Two 1/4 straight track  
Two 1/4 straight track, female  
Two 60-degree track, male  
One 90-degree track, female

Two 3/4 straight track  
One 1/4 straight track, male  
One 60-degree track, female  
One cross track  
One 90-degree track, male



Two label sheets  
One user's manual

## WARNING:

All packing materials, such as tape, plastic sheets, packaging locks and tags are not part of this toy, and should be discarded for your child's safety.

## ATTENTION:

Pour la sécurité de votre enfant, débarrassez-vous de tous les produits d'emballage tels que rubans adhésifs, feuilles de plastique, attaches et étiquettes. Ils ne font pas partie du jouet.

## NOTE:

Please keep this user's manual as it contains important information.



## CAUTION:

Adult assembly required. This package contains small screws. For your child's safety, do not let your child play with the toy until it is fully assembled.

# GETTING STARTED

## BATTERY INSTALLATION – RACE CAR

1. Make sure the unit is turned **OFF**.
2. Locate the battery cover on the bottom of the race car. Use a coin or a screwdriver to loosen the screw.
3. Install 2 new “AAA” (AM-4/LR03) batteries following the diagram inside the battery box. (The use of new alkaline batteries is recommended for maximum performance.)
4. Replace the battery cover and tighten the screw to secure the battery cover.

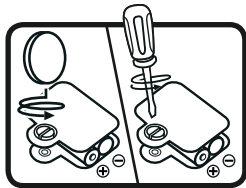

## BATTERY INSTALLATION – ELECTRONIC PIT STOP

1. Make sure the unit is turned **OFF**.
2. Locate the battery cover on the right side of the electronic pit stop. Use a screwdriver to loosen the screw.
3. Install 2 new “AAA” (AM-4/LR03) batteries following the diagram inside the battery box. (The use of new alkaline batteries is recommended for maximum performance.)
4. Replace the battery cover and tighten the screw to secure the battery cover.

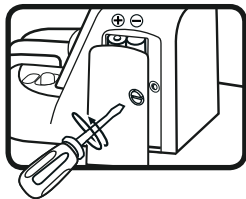

## BATTERY NOTICE

- Use new alkaline batteries for maximum performance.
- Use only batteries of the same or equivalent type as recommended.
- Do not mix different types of batteries: alkaline, standard (carbon-zinc) or rechargeable (Ni-Cd, Ni-MH), or new and used batteries.
- Do not use damaged batteries.
- Insert batteries with the correct polarity.
- Do not short-circuit the battery terminals.
- Remove exhausted batteries from the toy.
- Remove batteries during long periods of non-use.
- Do not dispose of batteries in fire.
- Do not charge non-rechargeable batteries.
- Remove rechargeable batteries from the toy before charging (if removable).
- Rechargeable batteries are only to be charged under adult supervision.

Please adhere the labels to the playset securely as indicated below:

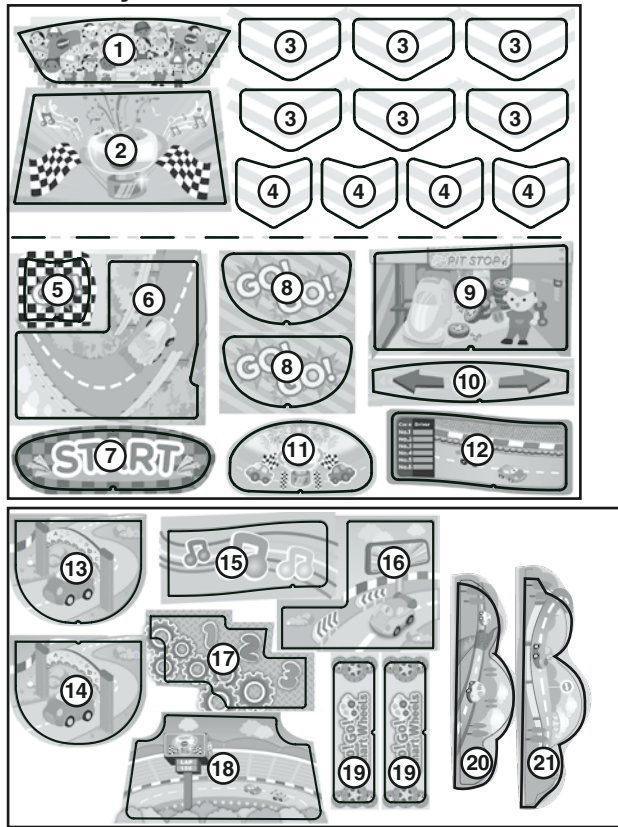

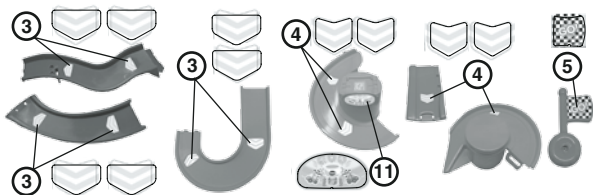
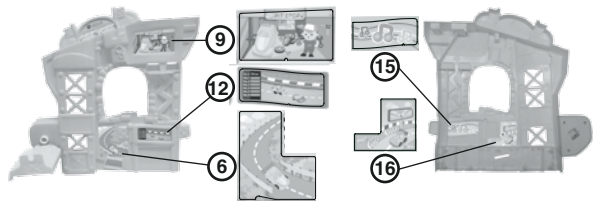
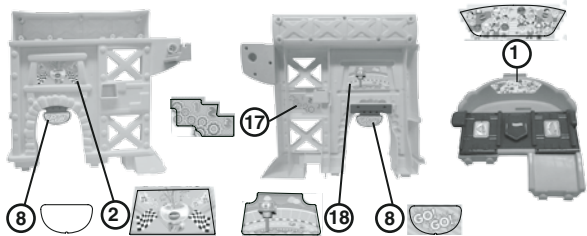

# ASSEMBLY INSTRUCTIONS

With the VTech® Go! Go! Smart Wheels® Ultimate Amazement Park Playset™, safety comes first. To ensure your child's safety, adult assembly is required. You will need a Phillips head screwdriver to assemble the playset (not included).

## Assemble the Tower

1. Insert the big tower piece with the archway on the bottom into the slots on the tower base. Then turn the pieces upside-down and push down firmly until the pieces “click” into place. Insert the second big tower piece into the slots located on the top of the first tower piece. Use a screwdriver to fasten seven screws into the holes on the back of the lower tower piece.

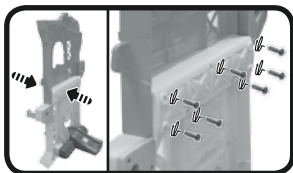
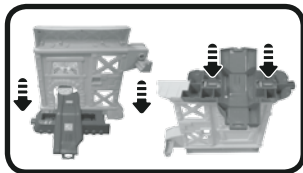

2. Attach the flag to the launcher using a screw. Then insert the launcher into the slots on the top of the fully assembled tower piece. You should hear a “click” sound to indicate that the pieces are secure.

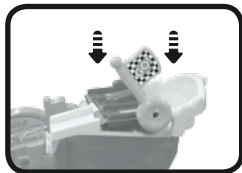
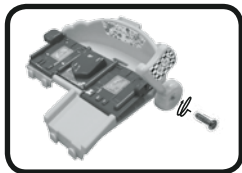

## Assemble the 360 Degree Loop Course

1. Place the loop track base on the left side of the assembled tower. Use the base support to connect the tower and loop base. Then insert the semicircular loop track into the slots on the top of the loop track base as shown until you hear them “click” into place.

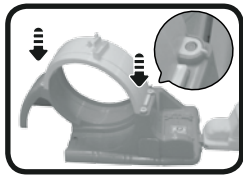
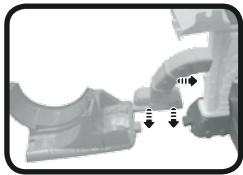

2. Insert the small track support piece into the slot on the back of the tower as shown. Then connect the two long straight tracks together. Insert the hooked end into the left side of the launcher and insert the opposite end of the long track into the slot on the loop track base until you hear them “click” into place. The fully assembled long track should be attached to the notch on the small track support piece.

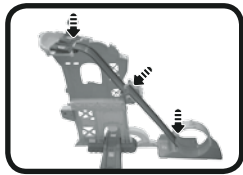
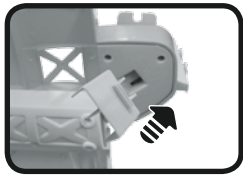

## Assemble the Spiral Course

1. Slide the longer C-shaped track onto the notches located on the right side of the launcher so it snaps into place. Then pass the shorter C-shaped track through the archway on the top tower piece and connect it to the end of the longer C-shaped track. Once connected, insert the notch that is located at the base of the archway into the hole that is located on the bottom of the shorter C-shaped track until it snaps into place.

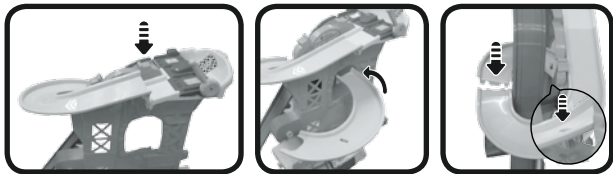

2. Snap the short straight track into the slot on the front of the tower base. Assemble the spiral track by joining the two spiral track pieces together making sure the piece with a **SmartPoint**<sup>®</sup> is on top. Then insert the assembled spiral into the holes located on the bottom tower piece and the short straight track until you hear them “click” into place.



#### 4. Assemble the Ramp Course

Insert the long curved track with two circular holes into the slot on the left side of the top tower piece as shown. Position the notch located on the bottom of this curved track into the slot located on the top of the loop track. Use a screwdriver to fasten two screws into the holes on the track. After that, attach the other long curved track to the end of the ramp.





## 5. Finish the Assembly

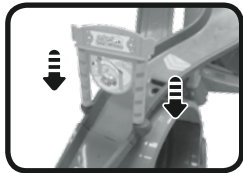
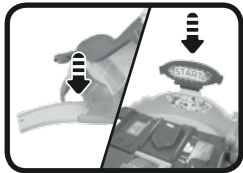
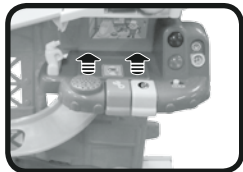
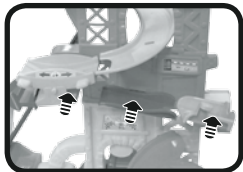

Insert the rocking platform, mini ramp track, flip-down platform and the electronic pit stop into the holes on the tower as shown until you hear them click into place. Insert the start piece into the slot on the top of the launcher and place the last short curved track at the end of the loop base. Finally, attach the flipping board to the gate, then insert the gate into the slots on the long curved track.



Once you've completed the above steps, you are ready to play! Using the included track pieces, you can configure the **Go! Go! Smart Wheels® Ultimate Amazement Park™** in different ways! You can also connect these track pieces to other **Go! Go! Smart Wheels®**, **Go! Go! Smart Animals®** and select **Go! Go! Smart Friends®** playsets. (Each sold separately.) For optimal performance, please play with your **Ultimate Amazement Park Playset™** on a sturdy and smooth surface.

# PRODUCT FEATURES – RACE CAR

## 1. ON/OFF SWITCH

To turn the race car **ON**, slide the **ON/OFF SWITCH** on the race car to the **ON** (  ) position. To turn the race car **OFF**, slide the **ON/OFF SWITCH** to the **OFF** (  ) position.

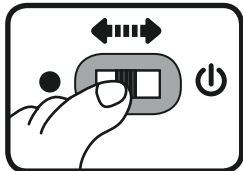

## 2. AUTOMATIC SHUT-OFF

To preserve battery life, the race car included with the **VTech® Go! Go! Smart Wheels® Ultimate Amazement Park Playset™** will automatically power-down after approximately 60 seconds without input. The unit can be turned on again by pressing the light-up driver button or pushing the race car quickly.

**Note:** This product is in a try-me mode in the packaging. After opening the package, turn the vehicle off and on again to proceed with normal play.

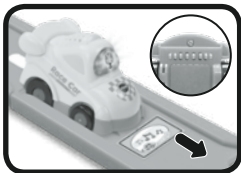
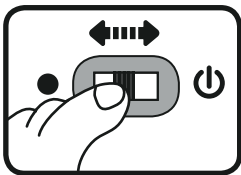

# ACTIVITIES - RACE CAR

1. Slide the **ON/OFF SWITCH** to turn the unit **ON**. You will hear race car sounds, a song and a phrase. The light will flash with the sounds.
2. Press the **LIGHT-UP DRIVER BUTTON** to hear race car sounds, songs and phrases. The light will flash with the sounds.
3. Push the race car to hear fun sounds and melodies. While the melody is playing, push the race car again to add in fun sounds on top of the melody. The light will flash with the sounds.
4. For added fun, the race car interacts with the **VTech® Go! Go! Smart Wheels® Ultimate Amazement Park Playset™**. Simply roll the race car over one of the playset's eight **SmartPoint®** locations to see the race car's light flash and to hear greetings, fun sounds, short tunes and sing-along songs. The race car even interacts with other **Go! Go! Smart Wheels®** and **Go! Go! Smart Animals®** playsets (each playset sold separately).



# PRODUCT FEATURES – ELECTRONIC PIT STOP

## 1. ON/OFF/VOLUME CONTROL SWITCH

To turn the unit **ON**, slide the **ON/OFF/VOLUME CONTROL SWITCH** to the low volume (  ) or high volume (  ) position. To turn the unit **OFF**, slide the **ON/OFF/VOLUME CONTROL SWITCH** to the **OFF** (  ) position.

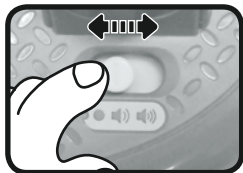

## 2. MODE SELECTOR SWITCH

The electronic pit stop has two modes of play: **Play Mode** and **Music Mode**. Slide the **MODE SELECTOR SWITCH** to choose a mode of play.

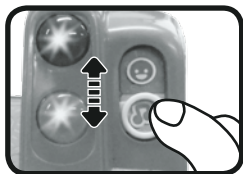

## 3. AUTOMATIC SHUT-OFF

To preserve battery life, the electronic pit stop will automatically power-down after approximately 30 seconds without input. The unit can be re-activated by playing with any button or switch on the electronic pit stop.

# ACTIVITIES - ELECTRONIC PIT STOP

1. Slide the **ON/OFF/VOLUME CONTROL SWITCH** to either volume setting to turn the unit **ON**. You will hear a song and a greeting. The lights will flash with the sounds.

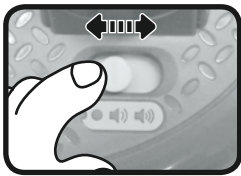

2. Slide the **MODE SELECTOR SWITCH** to choose a mode of play. You will hear an exciting song, fun sound effects or phrases depending on the selected mode. The light will flash with the sounds.

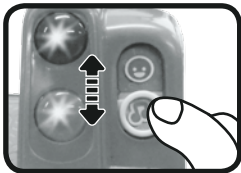

3. In **Play Mode**, press the wrench button or the tire button or wiggle the gas pump to learn colors, names and the functions of the tools. The light will flash with the sounds.

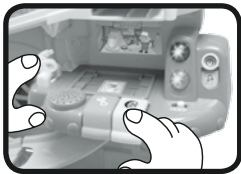

4. In **Music Mode**, press the wrench button or the tire button to play melodies. Wiggle the gas pump to play sing-along songs and melodies. While listening to the sing-along songs and melodies, play with any of the three buttons to add in fun sound effects on top of the music.

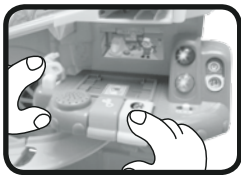

5. If there is no input after approximately 10 seconds, you will hear a sound effect and a reminder to play. After another 10 seconds of no input, the unit will play a short tune and then go into sleep mode. The unit can be reactivated by playing with any button or switch on the electronic pit stop.

## MELODY LIST

1. Pop! Goes the Weasel
2. Chopsticks
3. Can Can
4. Alouette
5. Humpty Dumpty
6. Oh Susannah
7. Camptown Races
8. Alphabet Song
9. Yankee Doodle
10. Jack Be Nimble
11. Take Me Out to the Ball Game
12. Daring Young Man on the Flying Trapeze
13. Shoo Fly, Don't Bother Me
14. The Animal Fair
15. Mary Had a Little Lamb

## SONG LYRICS

### SONG 1

Start your engines!  
Ready, get set, go!  
Finish the course!  
Don't be slow!

## SONG 2

Driving is amazing!  
Zooming! Zipping! Let's go fast!  
Loop-the-loop!  
Don't finish last!

## SONG 3

My car's fixed up, I'm ready to go!  
Beep! Beep! Hit the gas. . .let's go!

# PRODUCT FEATURES - AMAZEMENT PARK

## 1. SMARTPOINT® LOCATIONS

The **Ultimate Amazement Park Playset™** features eight different **SmartPoint®** locations that interact with the included race car or any other **Go! Go! Smart Wheels® SmartPoint®** vehicle (each sold separately). Simply roll the vehicle over each **SmartPoint®** to hear fun sounds, music and phrases.

## 2. LAUNCHER

To move your race car down one of three fun courses, place it on one of the two **SmartPoint®** locations on the launcher at the top of the toy. Pull the flag and watch the car zip down!

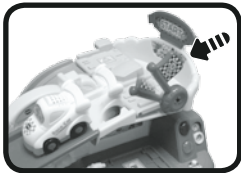

**WARNING:** When launching the car, do not place your face in front of the course and ramp exits.

### 3. ROCKING PLATFORM

When your car lands on the **ROCKING PLATFORM**, push it down to the left or right to move your race car forward and backward.

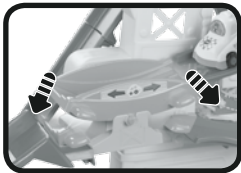

### 4. FLIP-DOWN PLATFORM

To move your car down to the **SPIRAL COURSE**, press down on the **FLIP-DOWN PLATFORM** to watch your race car go down.



**Note:** For optimal performance on the **Ultimate Amazement Park Playset's** three courses, please use the included vehicle.

## CARE & MAINTENANCE

1. Keep the unit clean by wiping it with a slightly damp cloth.
2. Keep the unit out of direct sunlight and away from any direct heat source.
3. Remove the batteries when the unit will not be in use for an extended period of time.
4. Do not drop the unit on hard surfaces and do not expose the unit to moisture or water.



# TROUBLESHOOTING

If for some reason the program/activity stops working or malfunctions, please follow these steps:

1. Please turn the unit **OFF**.
2. Interrupt the power supply by removing the batteries.
3. Let the unit sit for a few minutes, then replace the batteries.
4. Turn the unit **ON**. The unit should now be ready to play again.
5. If the product still does not work, replace with an entire set of new batteries.

If the problem persists, please call our Consumer Services Department at 1-800-521-2010 in the U.S. or 1-877-352-8697 in Canada, and a service representative will be happy to help you.

For information on this product's warranty, please call VTech® at 1-800-521-2010 in the U.S. or 1-877-352-8697 in Canada.

## **IMPORTANT NOTE:**

Creating and developing **Infant Learning** products is accompanied by a responsibility that we at **VTech®** take very seriously. We make every effort to ensure the accuracy of the information, which forms the value of our products. However, errors sometimes can occur. It is important for you to know that we stand behind our products and encourage you to call our Consumer Services Department at 1-800-521-2010 in the U.S. or 1-877-352-8697 in Canada, with any problems and/or suggestions that you might have. A service representative will be happy to help you.

**Note:**

This equipment has been tested and found to comply with the limits for a Class B digital device, pursuant to Part 15 of the FCC Rules. These limits are designed to provide reasonable protection against harmful interference in a residential installation. This equipment generates, uses and can radiate radio frequency energy and, if not installed and used in accordance with the instructions, may cause harmful interference to radio communications. However, there is no guarantee that interference will not occur in a particular installation. If this equipment does cause harmful interference to radio or television reception, which can be determined by turning the equipment off and on, the user is encouraged to try to correct the interference by one or more of the following measures:

- Reorient or relocate the receiving antenna.
- Increase the separation between the equipment and receiver.
- Connect the equipment into an outlet on a circuit different from that to which the receiver is connected.
- Consult the dealer or an experienced radio/TV technician for help.

**Caution:** Changes or modifications not expressly approved by the party responsible for compliance could void the user's authority to operate the equipment.

THIS DEVICE COMPLIES WITH PART 15 OF THE FCC RULES. OPERATION IS SUBJECT TO THE FOLLOWING TWO CONDITIONS:  
(1) THIS DEVICE MAY NOT CAUSE HARMFUL INTERFERENCE, AND  
(2) THIS DEVICE MUST ACCEPT ANY INTERFERENCE RECEIVED, INCLUDING INTERFERENCE THAT MAY CAUSE UNDESIRED OPERATION.

*CAN ICES-3 (B)/NMB-3(B)*



## PRODUCT WARRANTY

This Warranty is applicable only to the original purchaser, is non-transferable and applies only to "VTech" products or parts. This product is covered by a 3-month Warranty from the original purchase date, under normal use and service, against defective workmanship and materials. This Warranty does not apply to (a) consumable parts, such as batteries; (b) cosmetic damage, including but not limited to scratches and dents; (c) damage caused by use with non-VTech products; (d) damage caused by accident, misuse, unreasonable use, immersion in water, neglect, abuse, battery leakage, or improper installation, improper service, or other external causes; (e) damage caused by operating the product outside the permitted or intended uses described by VTech in the owner's manual; (f) a product or part that has been modified (g) defects caused by normal wear and tear or otherwise due to the normal aging of the product; or (h) if any VTech serial number has been removed or defaced.

Prior to returning a product for any reason, please notify the VTech Consumer Services Department, by sending an email to [vtechkids@vtechkids.com](mailto:vtechkids@vtechkids.com) or calling 1-800-521-2010. If the service representative is unable to resolve the issue, you will be provided instructions on how to return the product and have it replaced under Warranty. Return of the product under Warranty must adhere to the following rules:

If VTech believes that there may be a defect in the materials or workmanship of the product and can confirm the purchase date and location of the product, we will at our discretion replace the product with a new unit or product of comparable value. A replacement product or parts assumes the remaining Warranty of the original product or 30 days from the date of replacement, whichever provides longer coverage.

THIS WARRANTY AND THE REMEDIES SET FORTH ABOVE ARE EXCLUSIVE AND IN LIEU OF ALL OTHER WARRANTIES, REMEDIES AND CONDITIONS, WHETHER ORAL, WRITTEN, STATUTORY, EXPRESS OR IMPLIED. IF VTECH CANNOT LAWFULLY DISCLAIM STATUTORY OR IMPLIED WARRANTIES THEN TO THE EXTENT PERMITTED BY LAW, ALL SUCH WARRANTIES SHALL BE LIMITED TO THE DURATION OF THE EXPRESS WARRANTY AND TO THE REPLACEMENT SERVICE AS DETERMINED BY VTECH IN ITS SOLE DISCRETION.

To the extent permitted by law, VTech will not be responsible for direct, special, incidental or consequential damages resulting from any breach of Warranty.

This Warranty is not intended to persons or entities outside the United States of America. Any disputes resulting from this Warranty shall be subject to the final and conclusive determination of VTech.